

RoHS Compliant 

THIS DRAWING CONTAINS INFORMATION THAT IS PROPRIETARY TO ZDT TECHNOLOGY, AND SHOULD NOT BE USED WITHOUT WRITTEN PERMISSION

REV	ECN No.	DATE	REMARK
A0	NEW	2019.11.21	NEW RELEASE

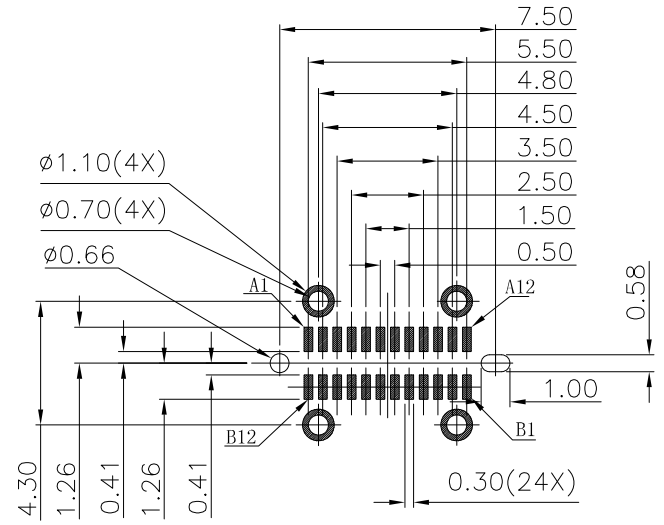
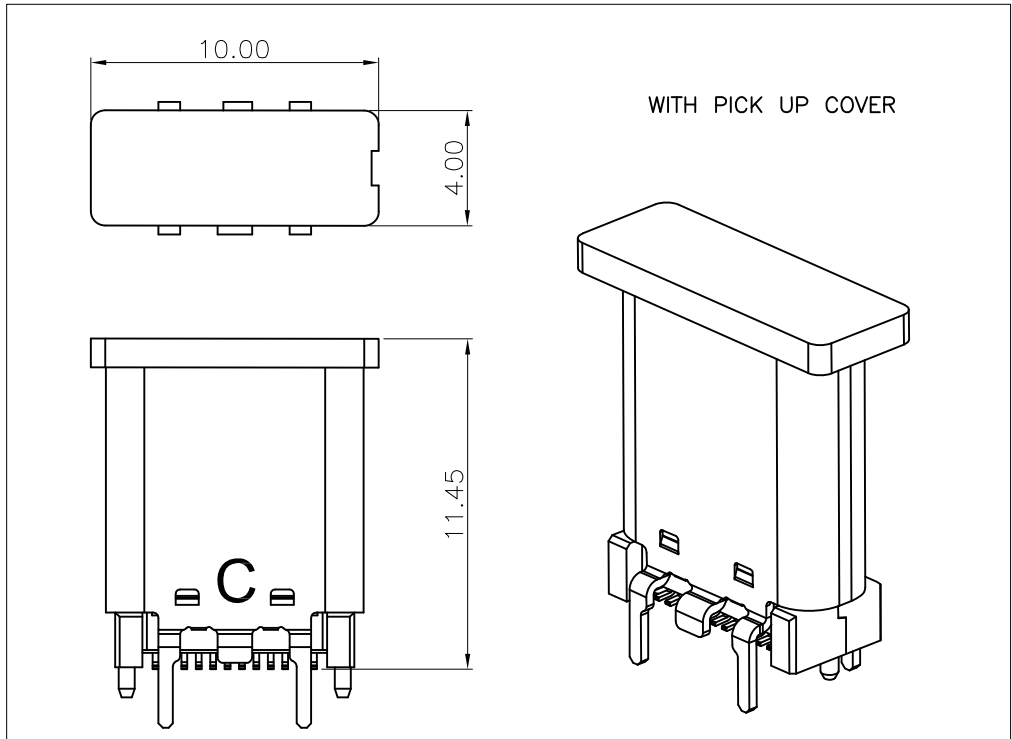

USB TYPE-C PIN ASSIGNMENTS

PIN NUMBER	SIGNAL NAME	PIN NUMBER	SIGNAL NAME
A1	GND	B12	GND
A2	SSTXp1	B11	SSRXp1
A3	SSTXn1	B10	SSRXn1
A4	Vbus	B9	Vbus
A5	CC1	B8	SBU2
A6	Dp1	B7	Dn2
A7	Dn1	B6	Dp2
A8	SBU1	B5	CC2
A9	Vbus	B4	Vbus
A10	SSRXn2	B3	SSTXn2
A11	SSRXp2	B2	SSTXp2
A12	GND	B1	GND

RECOMMENDED PCB LAYOUT(TOP VIEW)
THICKNESS 2.0±0.10MM;DEFAULT TOLERANCE:±0.05

PART NO.: SEE THE PART NUMBER CODE		GOLDCONN TECHNOLOGIES COMPANY LIMITED		DRAWN BY SAM	DATE 2019.11.21	
QUALITY SYMBOL 0 0 0 0 0	GENERAL TOLERANCES (UNLESS SPECIFIED)		TITLE USB 3.1 TYPE C FEMALE VERTICAL H=10.4mm SMT TYPE脚长2.1三次成型			
	x.xxxx	± ---	DWG.NO. CF176-24-C3	SHEET NO. 2 OF 2	CHECKED BY JAY	DATE 2019.11.21
	x.xxx	± 0.10			APPROVED BY JACKY	DATE 2019.11.21
	x.xx	± 0.25	DIMENSION STYLE MM ONLY		DESIGN UNITS METRIC	THIRD ANGLE PROJECTION
	x.x	± 0.30	SCALE 1:1			
ANGULAR	± ---°					

frame size: A4