

- NOTES:
- MATERIAL SPECIFICATION:
 - 1-1.HOUSING:High-Temp Plastics,UL94V-0,Color:Black.
 - 1-2.CONTACTS:Copper Alloy T=0.25mm.
 - 1-3.OUTER SHELL:Stainless Steel,T=0.30mm.
 - 1-4.INNER SHELL:Stainless Steel,T=0.20mm.
 - 1-5.MID-PLATE:Stainless Steel,T=0.20mm.
 - 1-6.SOLDER-PLATE:Stainless Steel,T=0.10mm.
 - PLATING SPECIFICATION:
 - 2-1.CONTACTS:
 - Ni UNDERPLATED OVER ALL;
 - Gold Plated On Contact Area;
 - Gold Flash Plated On Solder Area.
 - 2-2.SHELL:
 - Ni UNDERPLATED OVER ALL;
 - Gold Flash Plated On Solder Leg.
 - RoHS AND HF COMPLIANT.
 - MECHANICAL PERFORMANCE:
 - 4-1.MATING FORCE:6~20N (Initial);5~20N (After)
 - 4-2.UNMATING FORCE:8~20N (Initial);6~20N (After)
 - 4-3.DURABILITY:10000 CYCLES.
 - ELECTRICAL PERFORMANCE:
 - 5-1.CURRENT RATING:5A;VOLTAGE RATING:20V
 - 5-2.LLCCR:
 - VBUS & GND PINS:40mA/PIN MAX.;
 - OTHERS PINS:40mA/PIN MAX.;
 - LLCCR MAX. CHANGE OF ALL PINS:10mA.
 - 5-3.INSULATION RESISTANCE:100MΩ MIN.
 - 5-4.DIELECTRIC WITHSTANDING VOLTAGE:
 - 100V AC FOR 1 MINUTE.
 - ENVIRONMENTAL PERFORMANCE:
 - OPERATING TEMPERATURE:-20℃~+85℃.
 - RECOMMENDED PROCESS:
 - THE PEAK TEMPERATURE ON THE BOARD SHALL MAINTAIN 10±1 SECONDS AT 260±5℃.
 - PART NUMBER CODE:(产品料号)
CF190-16S X X XX R - G7
(1) (2) (3) (4)
- (1) HOUSING MATERIAL: C:PA9T
(2) HOUSING COLOR: B:BLACK
(3) CONTACTS PLATED: 12:接触镀金3U. 其它OF
(4) PACKING OPTIONS R:TAPE & REEL

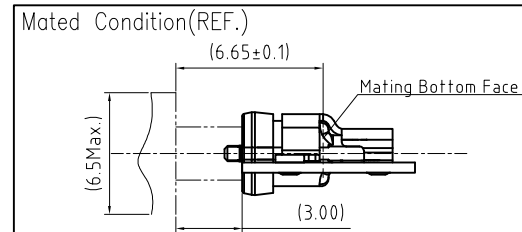
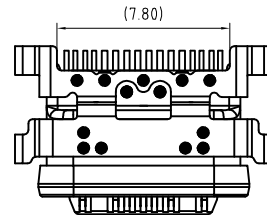
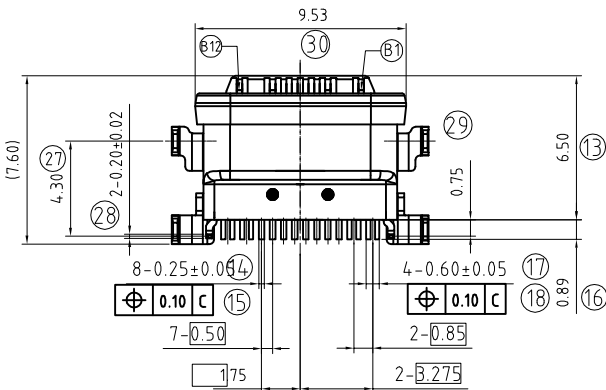
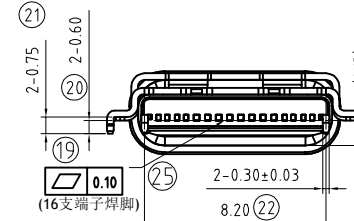
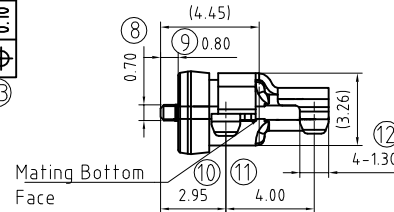
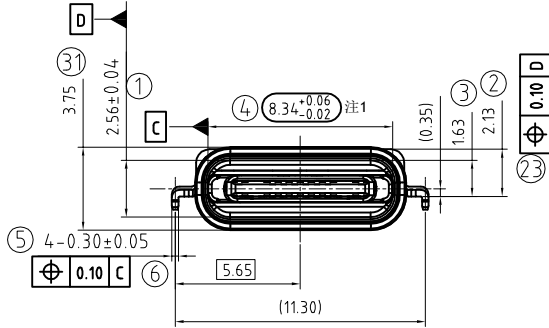

Pin Assignments

Contact Number	Signal Name	Contact Number	Signal Name
A1	GND	B12	GND
A4	VBUS	B9	VBUS
A5	CC1	B8	SBU2
A6	Dp1	B7	Dn2
A7	Dn1	B6	Dp2
A8	SBU1	B5	CC2
A9	VBUS	B4	VBUS
A12	GND	B1	GND

PART NO.:
SEE THE PART NUMBER CODE

GOLDCONN TECHNOLOGIES COMPANY LIMITED

DRAWN BY: SAM
DATE: 2021.12.15

QUALITY SYMBOL	GENERAL TOLERANCES (UNLESS SPECIFIED)
	x.xxxxx
	x.xxxx
	x.xx
	x.x
ANGULAR	---

TITLE USB Type-C 母 16pin 防水型,IPX7,沉板1.13,外露0.8		SHEET NO. 1 OF 1	
DWG.NO. CF190-16-G7	DESIGN UNITS METRIC	SCALE 1:1	
DIMENSION STYLE MM ONLY			

CHECKED BY: JAY
DATE: 2021.12.15

APPROVED BY: JACKY
DATE: 2021.12.15

