

REV	ECN No.	DATE	REMARK
D	NEW	2024.12.05	1. 内壳由原来的不电镀改为镀镍; 2. 外壳激光焊点由原来的1个焊点改为2点
E	ECR250308-005	2025.03.08	1. 拉伸壳取消电镀镍 2. 变更molding减胶

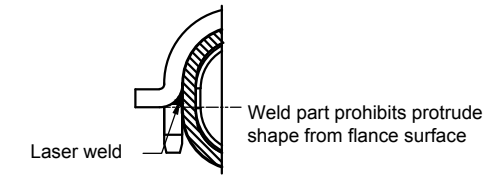

SECTION C-C
SCALE 2:1

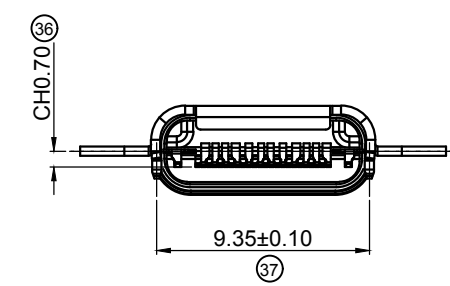
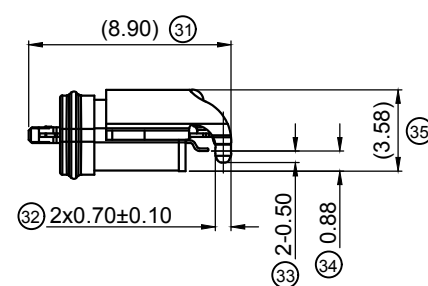
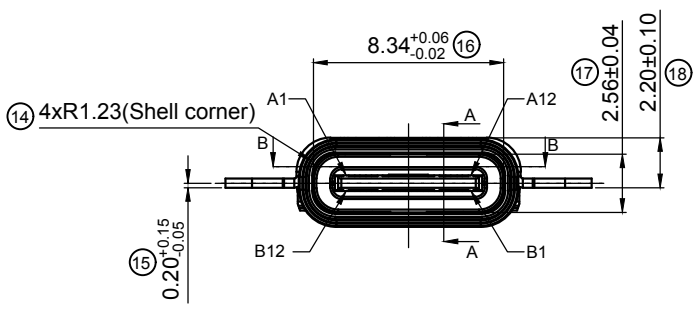
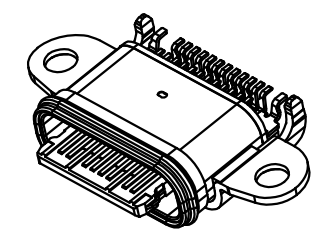
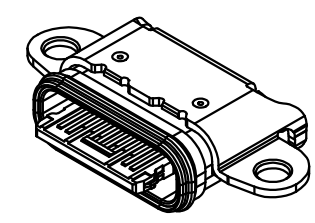
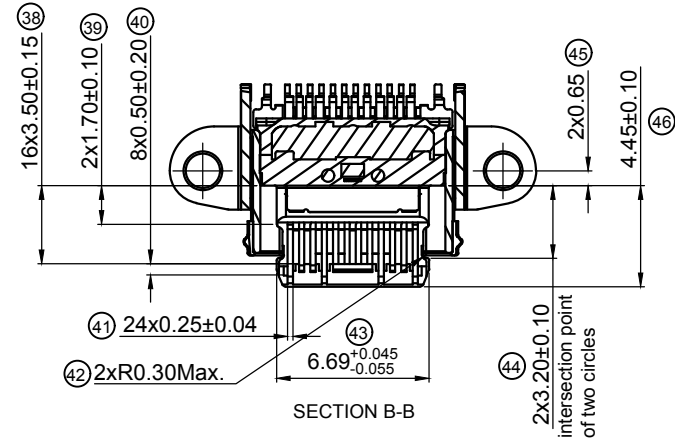
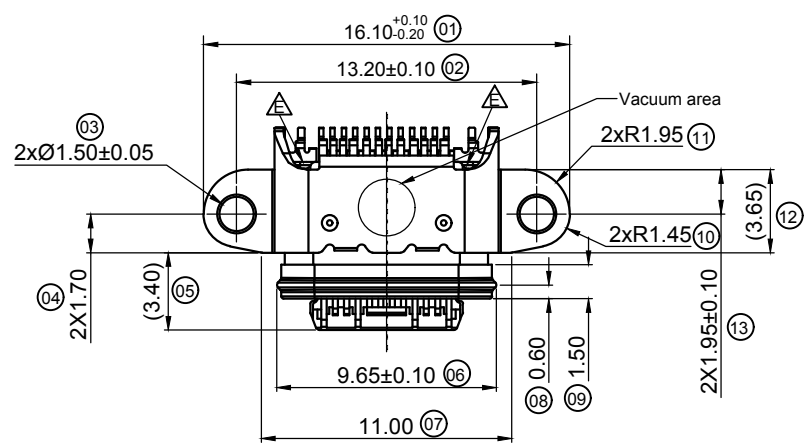
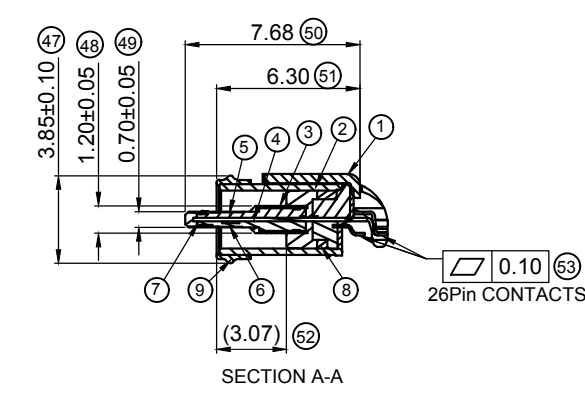
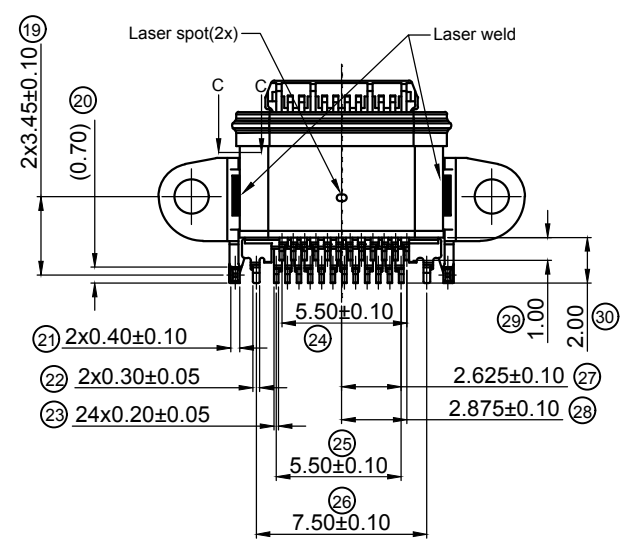
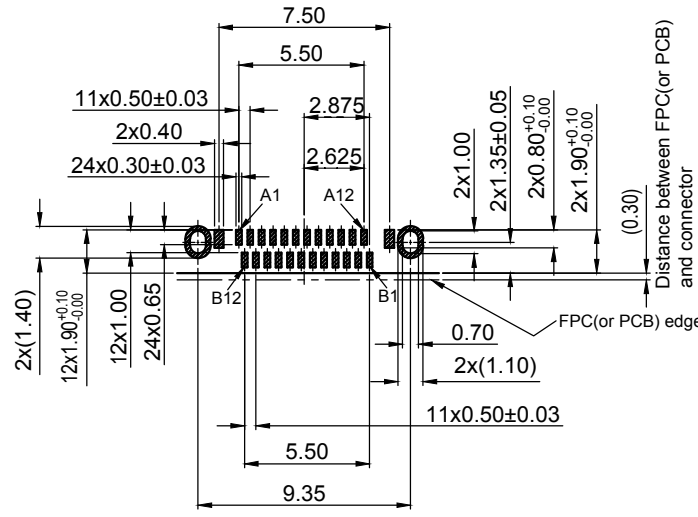

Table:

9	Liquid Rubber	1PCS	Si:CHN-LIMS-50-A/B	Color:Black, 50±10DEGREES
8	Rubber	--	Si:8935	Color:Black, 20±10DEGREES
7	Insertmolding	1PCS	LCP E6808	Color:Black UL94 V-0
6	Bottom Contact	12PCS	C18150-R540, T=0.12	Mating Area: Ni 50u"MIN.+Au 30u" Min.
5	Top Contact	12PCS	C18150-R540, T=0.12	Solder Tails: Ni 50u"MIN.+Au 1u" Min.
4	Mid Plate	1PCS	SUS301R-H, T=0.15	Ni 50u"Min.+Solder area: Au 1u"Min.
3	GND Plate	2PCS	SUS301R-H, T=0.10	None
2	Shell	1PCS	SUS316, T=0.30	None
1	Frame	1PCS	SUS304R-1/2H, T=0.30	MATT Ni:50u" Min.
NO.	Part Name	QTY	Material	Finish

GENERAL TOLERANCES (UNLESS SPECIFIED)		DRAWN BY: HuangXiaoHao		Date: 2025.03.08		GOLDCONN TECHNOLOGIES COMPANY LIMITED	
X.XXX	±0.10	CHECKED BY: liuzongliang		Date: 2025.03.08		TITLE USB Type-C Female 24Pin Waterproof Mid-Mount,CH0.7,Dual Row SMT Type	
X.XX	±0.25	APPROVED BY: Jacky		Date: 2025.03.08		PART NO. Ordering Information	
X.X	±0.30	THIRD ANGLE PROJECTION		SCALE: 1:1		DWG NO. CF246-24-C3	
ANGULAR	±3°	UNT	mm	DRAWING	SHEET NO.	REV.	
				A4	1 OF 3	A	

REV	ECN No.	DATE	REMARK
D	NEW	2024.12.05	1. 内壳由原来的不电镀改为镀镍; 2. 外壳激光焊点由原来的1个焊点改为2点
E	ECR250308-005	2025.03.08	1. 拉伸壳取消电镀镍 2. 变更molding减胶



RECOMMENDED PCB LAYOUT
DEFAULT TOLERANCE: ±0.05

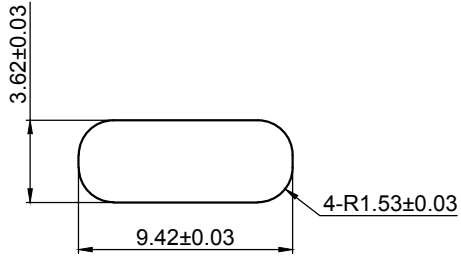

Section: D-D

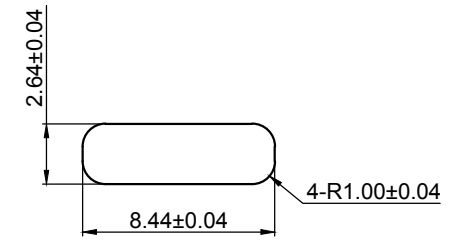

Section: E-E

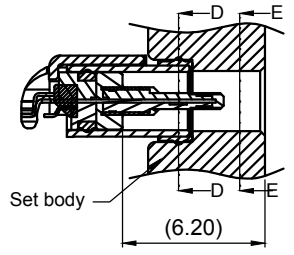

RECOMMENDED SET BODY
SIDE HOLE SHAPE

Remark:

- Mechanical Performance:
 - Insertion Force: 5~20N.
 - Extraction Force: 8~20N Initial, 6~20N After Test;
 - Durability: 10000 Cycles.
- Electrical Performance,
 - Current rating: 5.0 A max. For Vbus Pins.
1.25 A For Vconn Pin And Gnd Pins,
0.25 A For All of Other Pins.
Voltage Rating: 21V Max.
 - Contact Resistance: 40mΩ Max
 - Insulation Resistance: 100MΩ Min
 - Dielectric Withstand Voltage, AC 100V For 1 Minute.
- The Waterproof Grade Is IPX8(2.0M Depth of Water 30Min).
- Environmental Characteristics
 - Salt Spray: 48H
 - IR Reflow: Peak Temperature 250±5°C (Time: 20S Max.)
 - Operating Temperature Range: -30°C to +85°C.
 - Storage Temperature Range: -30°C To +85°C.
 - Relative Humidity: 15~70%RH
- Comply To ROHS 2.0 & HF & Reach

Ordering Information:

CF246-24SL B 15 R - C3

1 2

- Housing Color:
- Black
- Contacts Plated:
- 15: Contact Area: Au 30u", Solder Tails: 1u"

USB Type-C Pin Assignments

Pin Number	Signal Name	Pin Number	Signal Name
A1	GND	B12	GND
A2	SSTXp1	B11	SSRXp1
A3	SSTXn1	B10	SSRXn1
A4	VBUS	B9	VBUS
A5	CC1	B8	SBU2
A6	Dp1	B7	Dn2
A7	Dn1	B6	Dp2
A8	SBU1	B5	CC2
A9	VBUS	B4	VBUS
A10	SSRXn2	B3	SSTXn2
A11	SSRXp2	B2	SSTXp2
A12	GND	B1	GND

GENERAL TOLERANCES (UNLESS SPECIFIED)		DRAWN BY: HuangXiaoHao	Date: 2025.03.08	GOLDCONN TECHNOLOGIES COMPANY LIMITED	
X.XXX	±0.10	CHECKED BY: liuzongliang	Date: 2025.03.08	TITLE USB Type-C Female 24Pin Waterproof Mid-Mount, CH0.7, Dual Row SMT Type	
X.XX	±0.25	APPROVED BY: Jacky	Date: 2025.03.08	PART NO. Ordering Information	DWG NO. CF246-24-C3
X.X	±0.30	THIRD ANGLE PROJECTION	UNT	DRAWING A4	SHEET NO. 2 OF 3
ANGULAR	±3°		SCALE 1:1	REV. A	

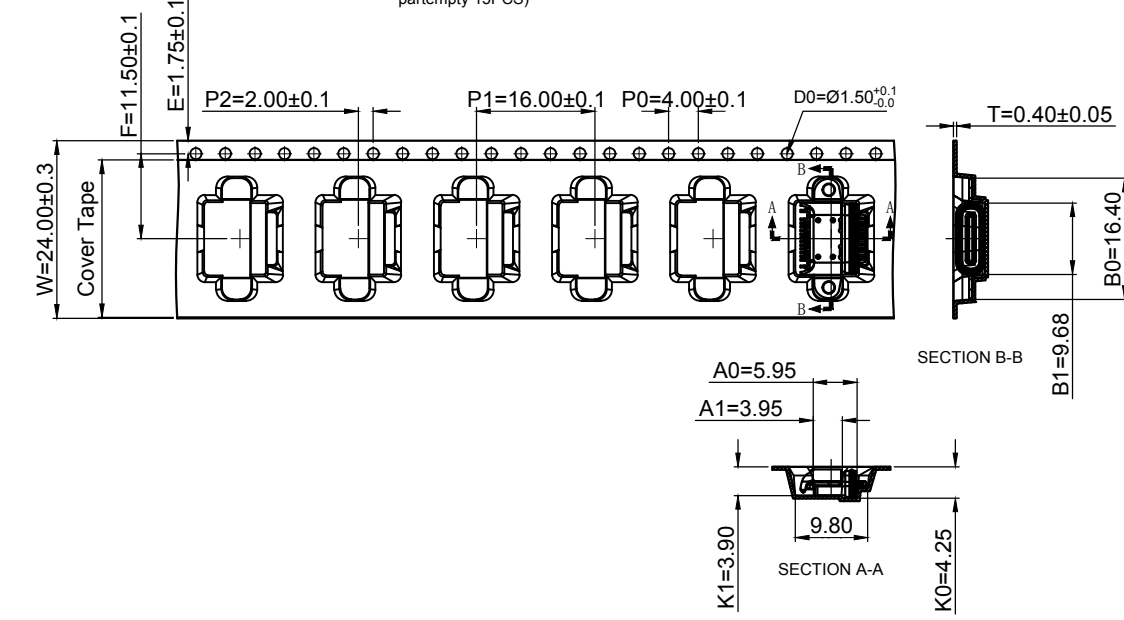
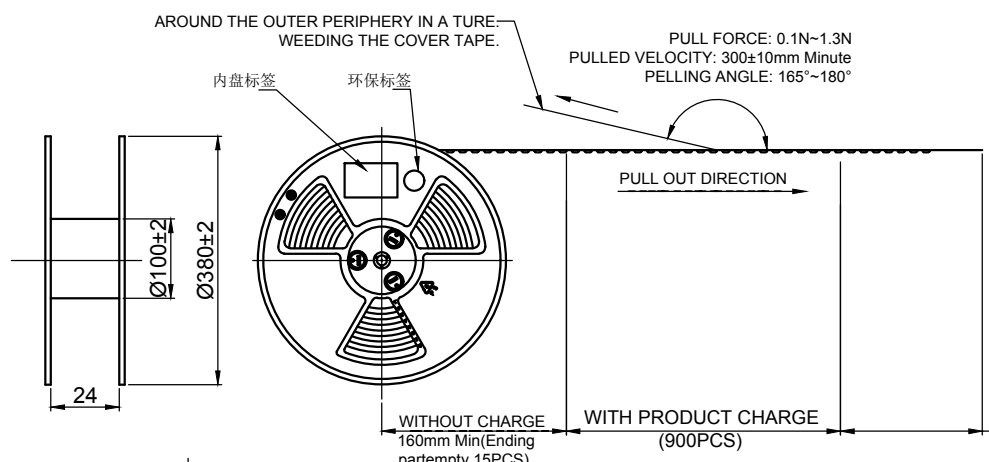

REV	ECN No.	DATE	REMARK
D	NEW	2024.12.05	1. 内壳由原来的不电镀改为镀镍; 2. 外壳激光焊点由原来的1个焊点改为2点
E	ECR250308-005	2025.03.08	1. 拉伸壳取消电镀镍 2. 变更molding减胶

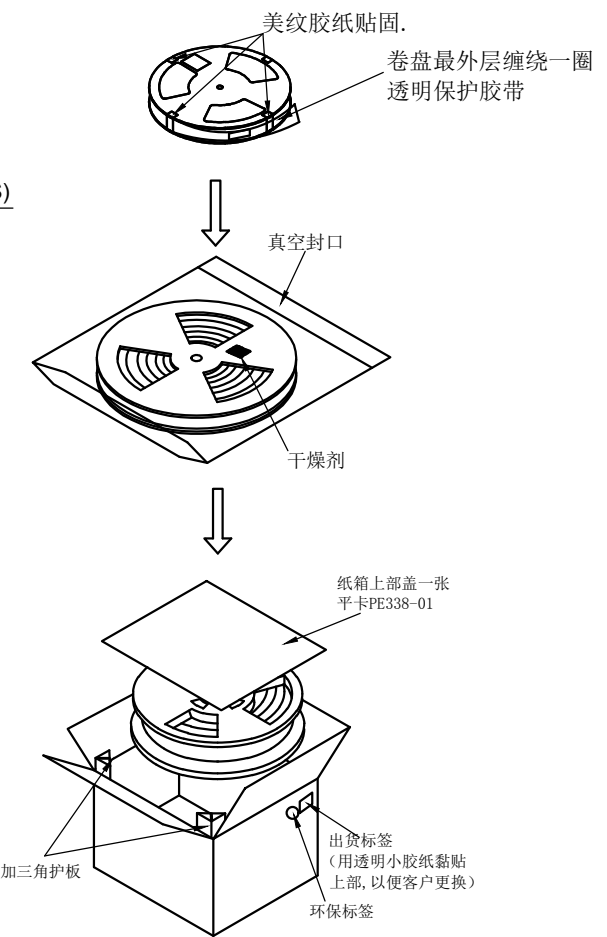

包装规范说明:

1. 如图所示首先CARRIER TAPE (载带) 需先预留15PCS空格后方可置入成品,并附COVER TPAE(上带)覆盖于上,再配合带装机自动卷绕于REEL(塑胶卷轴)收料。
As shown from picture, the initial starting carrier need to be emptied for 15 pcs, then put connector on lnth carrier; Then cover it with Cover Tape, and Reeling it with Reel auto machine.
2. 在定量包装完成后,前端CARRIER TAPE亦需预留15PCS空格,而COVER TPAE配合CARRIER TYPE长度覆盖后,并须再超出200mm以上,最后以胶纸贴固,最外圈用保护带缠绕一圈,并于REEL盘上方贴好标签。
In the end of the Reel, need to empty 15 pcs carrier tape; After covering the carrier, then the Cover Tape need to be 200mm longer, and use tape to fix the cover tape to the reel. Put unalified Label* on the tape.
3. 注意:COVER TAPE不可浮起或有贴附不顺,歪斜及成品放置方向错误之现象。
Attention: no deformation of Cover Tape is allowed (protruded plastic, or not smooth, bednt or product is wrong positioned)
4. 在纸箱内左右,前后侧各放入一块三角卡板,每个真空袋中装入1个REEL盘,并在PE袋中放入2PCS干燥剂,抽真空封好,在每个纸箱内装入10PCS卷盘,上面盖一张平卡,盖上箱盖后以胶带封箱,于侧位置贴好标签。
Inside of carton, at left and right side, put triangle fixed card; Put 1Reels to PE bag, and put 2 bags of desiccant inside the PE bag. Each carton has 10 reels. Put "Delivery label*" on side of the carton.
5. 零箱部分, 出货时须用缓冲物填满,特别注意: 尾数卷多余的空格子不能剪掉。
The fractional box must be filled by cushion before shipment.

产 品 规格	Product spc.	/
个 / 卷	Pcs/Reel	900
卷 / 箱	Reel/Clos.	10
个 / 箱	Pcs/Clos.	9000
重量	N. W.	/kg
(Kg)	G. W.	/kg

NO.	包材名称 Items	包材料号 Item no	用量 Usage	适用范围 Series	备注 / Remark
①	纸箱 Carton	PE338-B	1	广东省外,K=K	350*350*325mm
②	真空袋	PD085	10		480*460*0.17mm
③	carrier tape	PB292	10		W=21mm PET 透明14.88M/R
④	cover tape	P120122-01	1	自粘上带	W=21.3MM,200m/r透明色
⑤	塑胶卷轴 Plastic Reel	P120021-01	10		Ø330mm,W=30mm
⑥	干燥剂 Desiccant		4		
⑦	环保标签 Rohs Label		11		
⑧	合格标签 Qualified Label		10		80*35mm
⑨	出货标签 Delivery Label		1		80*50mm
⑩	保护带 Protect tape	PB284	1		W24*400M/R

GENERAL TOLERANCES (UNLESS SPECIFIED)		DRAWN BY: Date: HuangXiaoHao 2025.03.08		GOLDCONN TECHNOLOGIES COMPANY LIMITED	
X.XXX	±0.10	CHECKED BY: Date: liuzongliang 2025.03.08		TITLE USB Type-C Female 24Pin Waterproof Mid-Mount,CH0.7,Dual Row SMT Type	
X.XX	±0.25	APPROVED BY: Date: Jacky 2025.03.08		PART NO. Ordering Information	DWG NO. CF246-24-C3
X.X	±0.30			DRAWING A4	SHEET NO. 3 OF 3
ANGULAR	±3°			REV. A	
THIRD ANGLE PROJECTION		UNT	SCALE 1:1		