

TID No. 2154

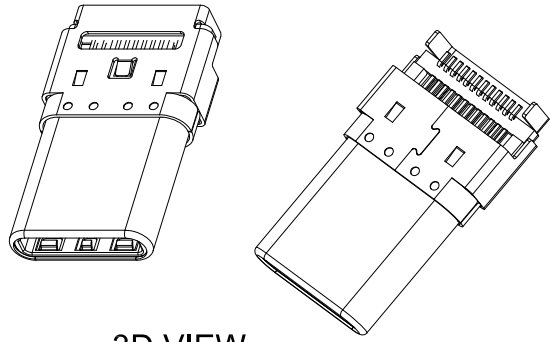

3D VIEW

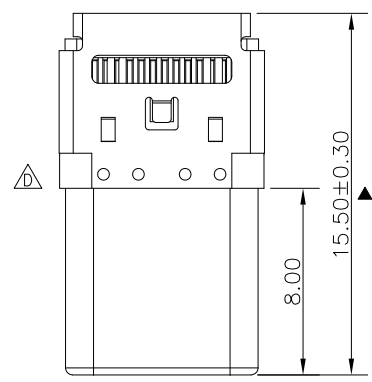
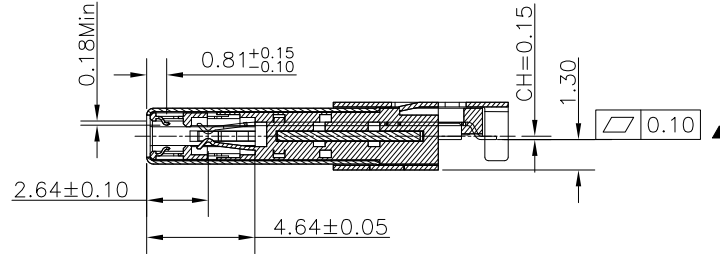
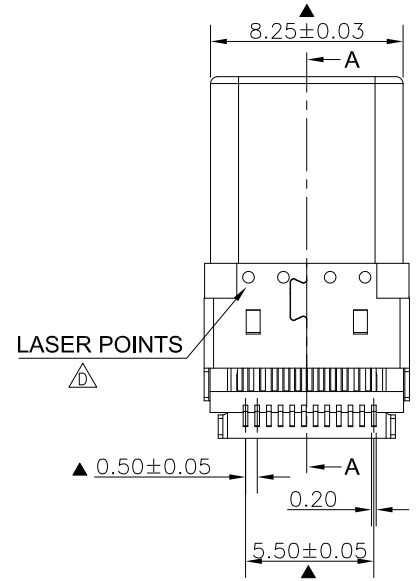
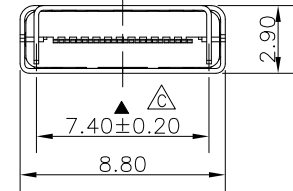
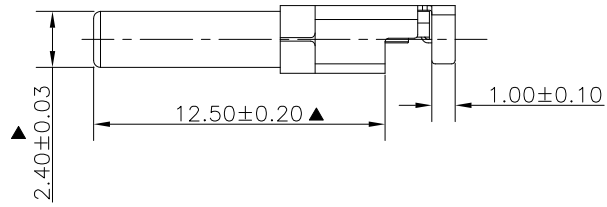
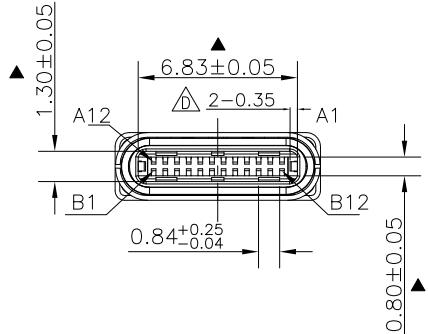

SECTION: A-A

REV	ECN No.	DATE	REMARK
A	NEW	2018.06.13	NEW RELEASE
B	ECN2003008	2020.03.19	增加MYLAR规格
C	ECN2006015	2020.06.16	修改铁壳脚7.4正负0.1公差改为正负0.2
D	ECN2009002	2020.09.02	依客人要求增加卡勾尺寸
E	ECN2011002	2020.11.10	增加真空包装料号规格
F	ECN2110001	2021.10.15	增加外壳镀黑镍规格
G	ECR2203001	2022.03.04	优化产品结构满足自动化生产要求
H	--	2022.04.29	增加外壳汗液测试规格
I	--	2023.08.02	更新焊点与实物相符
J	--	2024.05.25	增加重点尺寸标识

NOTE:
 1. Electrical Characteristics:
 Current Rating: 5A For Pin(A4,A9,B4,B9)
 1.25A For Others Pin
 Insulation Resistance: 100MΩ Min.
 Contact Resistance: 40 mΩ Max.
 Dielectric Withstanding Voltage:100V/AC 1Minute
 2. Mechanical Characteristics:
 Insertion Force: 5~20N
 Extraction Force: Initial: 8~20N
 After durability: 6~20N
 Durability :10000 Cycles
 3. Salt Spray :24H/48H
 4. Operating Temperature: -30°C TO +85°C
 5. 符合ROHS & HF要求.

6. With "▲" for the key control size
 7. PART NUMBER CODE:

CM073-24 X L B XX X C - X - 68
 (1) (2) (3) (4) (5) (6)

- △ (1) SHELL PLATED:
 无: 普通镍(常用料)
 J: 镀黑镍
- (2) HOUSING COLOR:
 B: BLACK
- (3) CONTACTS PLATED:
 02: 半金镀3u"
 05: 半金镀30u"
- (4) PACKING OPTIONS:
 R: TAPE & REEL
 VR: TAPE & REEL+真空包装(专用客户指定包装)
- (5) 带塞子选择:
 无: 无塞子
 C: 带塞子(常用料)
- (6) 盐雾规格:
 无: 24H
 C: 盐雾48H
 D: 外壳汗液测试 △

ITEM	NAME	QTY.	MATERIAL	DESCRIPTION
7	CAP	1	LCP UL94V-0	Color: Black
6	Shield	1	Stainless Steel SUS304	Nickel Plating
5	Housing	4	LCP UL94V-0	Color: Black
4	Latch	1	Stainless Steel SUS301	
3	Contact	24	Copper Alloy C7025	3u" gold plated on Contact area, Matte Tin plated on Solder tails, Nickel underplating over all
2	Emc Spring	2	Stainless Steel SUS304	
1	Shell	1	Stainless Steel SUS316L	Nickel Plating

PART NO.:		DRAWN BY:		GOLDCONN TECHNOLOGIES COMPANY LIMITED			
SEE THE PART NUMBER CODE		HuangXiaoHao					
GENERAL TOLERANCES		CHECKED BY:		TITLE			
x.xxxx	± ---	liuzongliang		USB TYPE-C PLUG SMT MIDDLE MOUNT			
x.xxx	± 0.10	APPROVED BY:		RIGHT ANGLE L=15.5MM			
x.xx	± 0.25	Jacky					
x.x	± 0.30	THIRD ANGLE PROJECTION					
ANGULAR	± 3'	DIMENSIONS		SCALE	DRAWING	SHEET NO.	DWG. NO.
		mm		1:1	A4	1 OF 2	CM073-24-68

带塞子尺寸示意图

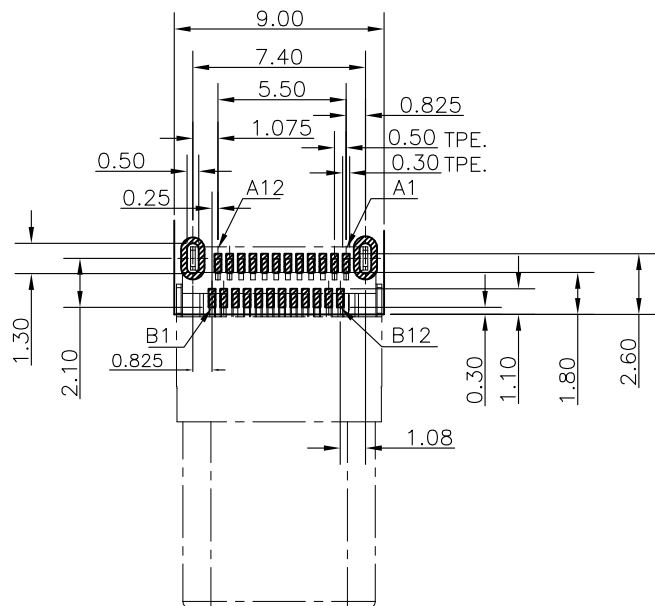
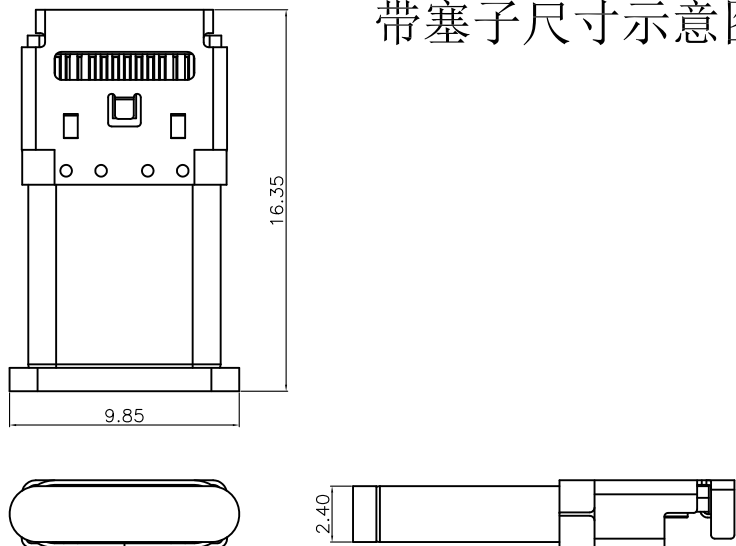

RECOMMENDED P.C.B. LAYOUT
T=0.80 OR 1.00mm
TOLERANCE UNSPECIFIED ±0.05mm

REV	ECN No.	DATE	REMARK
A	NEW	2018.06.13	NEW RELEASE
B	ECN2003008	2020.03.19	增加MYLAR规格
C	ECN2006015	2020.06.16	修改铁壳脚7.4正负0.1公差改为正负0.2
D	ECN2009002	2020.09.02	依客人要求增加卡勾尺寸
E	ECN2011002	2020.11.10	增加真空包装料号规格
F	ECN2110001	2021.10.15	增加外壳镀黑镍规格
G	ECR2203001	2022.03.04	优化产品结构满足自动化生产要求
H	--	2022.04.29	增加外壳汗液测试规格
I	--	2023.08.02	更新焊点与实物相符
J	--	2024.05.25	增加重点尺寸标识

USB TYPE-C PIN ASSIGNMENTS

PIN NUMBER	SIGNAL NAME	PIN NUMBER	SIGNAL NAME
A1	GND	B12	GND
A2	SSTXp1	B11	SSRXp1
A3	SSTXn1	B10	SSRXn1
A4	Vbus	B9	Vbus
A5	CC1	B8	SBU2
A6	Dp1	B7	Dn2
A7	Dn1	B6	Dp2
A8	SBU1	B5	CC2
A9	Vbus	B4	Vbus
A10	SSRXn2	B3	SSTXn2
A11	SSRXp2	B2	SSTXp2
A12	GND	B1	GND

PART NO.: SEE THE PART NUMBER CODE		DRAWN BY: HuangXiaoHao		GOLDCONN TECHNOLOGIES COMPANY LIMITED					
GENERAL TOLERANCES		CHECKED BY: liuzongliang		TITLE USB TYPE-C PLUG SMT MIDDLE MOUNT RIGHT ANGLE L=15.5MM					
x.xxxx	± ---	APPROVED BY: Jacky		THIRD ANGLE PROJECTION	DIMENSIONS	SCALE	DRAWING	SHEET NO.	DWG.NO.
x.xxx	± 0.10			mm	1:1	A4	2 OF 2	CM073-24-68	
x.xx	± 0.25								
x.x	± 0.30								
ANGULAR	± 3°								