

TID No. 10609

REV	ECN No.	DATE	REMARK
A	NEW	2020/07/12	NEW RELEASE
B	---	2023.05.24	变更新料号CM24012=>CM324-002
C	---	2024.02.16	改善客户外模冲胶, 取消外壳两侧卡点

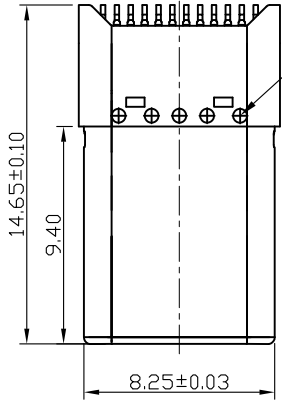

NOTE:
1.ELECTRICAL PERFORMANCE,
 1-1. CURRENT RATING:5 AMPS. FOR TOTAL VBUS/GND PINS;
 1.25AMPS FOR CC PIN,0.25 AMPS.
 FOR ALL OTHER CONTACT.
 1-2. VOLTAGE RATING:20V DC/AC (RMS. MAX)
 1-3. LLCR:.
 VBUS & GND PINS AND OTHER PINS: 40MΩ/PIN MAX.
 SHIELD:50MΩ/MAX.
 LLCR MAX. CHANGE OF ALL PINS: 10MΩ.
 1-4.INSULATION RESISTANCE: 100MΩ MIN
 1-5.DIELECTRIC WITHSTAND VOLTAGE,AC 100V FOR 1 MINUTE.
2.MECHANICAL PERFORMANCE,
 2-1.INSERTION FORCE: 5~20N.
 2-2.EXTRACTION FORCE: 8~20N.
 2-3.DURABILITY: 10000 CYCLES.
3.ENVIRONMENTAL PERFORMANCE:
 OPERATING TEMPERATURE: -30°C~+85°C.
4.IR REFLOW:
 THE PEAK TEMPERATURE ON THE BOARD SHALL
 BE MAINTAINED FOR 10 SECONDS AT 260°C.
5.COMPLIANCE WITH ROHS REQUIREMENTS.
6.SALT SPRAY:48H

PART NUMBER CODE:
 CM 3 24 - 002 S L B 01 R -X
 (1)(2) (3) (4) (5) (6) (7)

(1)Product type:
 3:MID-MOUNT
 (2)Pin No.:
 24:24Pin
 (3)HOUSING MATERIALS:
 L:LCP
 (4)HOUSING COLOR:
 B:BLACK
 (5)CONTACTS PLATED:
 01:半金锡1u"
 (6)PACKING OPTIONS:
 R:TAPE & REEL
 (7) 缺口选项:
 无:前壳两侧无缺口
 1:前壳两侧有缺口

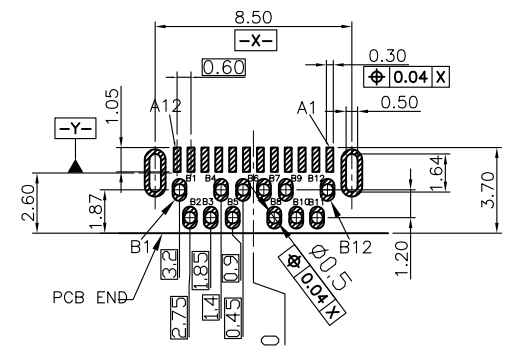
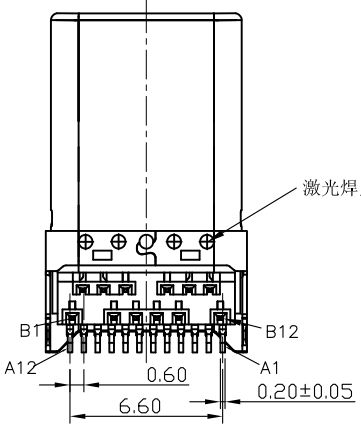
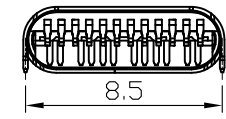
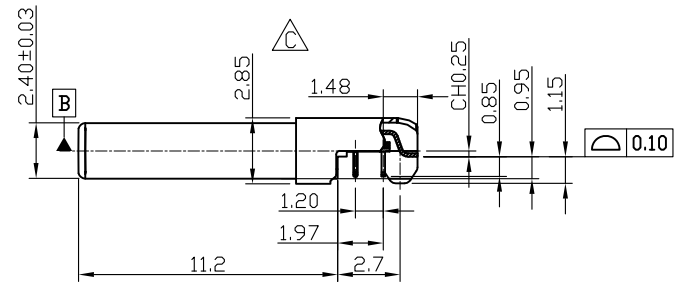
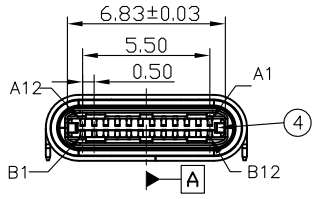
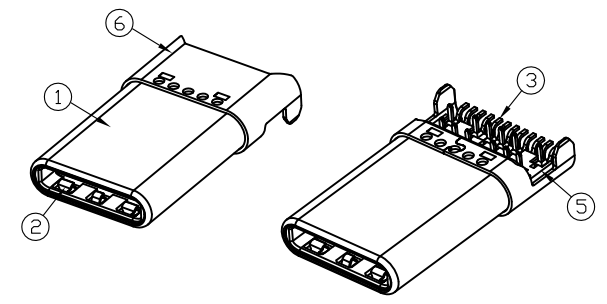

RECOMMEND P.C.B LAYOUT (THICKNESS 0.8mm)
 (COMPONENT SIDE) TOLERANCE±0.03mm

PIN DEFINITION:

PIN No.	A1	A2	A3	A4	A5	A6	A7	A8	A9	A10	A11	A12
SIGNAL NAME	GND	TX1+	TX1-	VBUS	CC1	D+	D-	SBU1	VBUS	RX2-	RX2+	GND

PIN No.	B12	B11	B10	B9	B8	B7	B6	B5	B4	B3	B2	B1
SIGNAL NAME	GND	RX1+	RX1-	VBUS	SBU2			CC2	VBUS	TX2-	TX2+	GND

ITEM	NAME	QTY.	MATERIAL	DESCRIPTION
6	Shield	1	Stainless Steel SUS201	Nickel Plating
5	Housing	4	LCP UL94V-0	Color: Black
4	Latch	1	Stainless Steel SUS301 T=0.40	
3	Contact	24	Copper Alloy C7025 T=0.15	1u"gold plated on Contact area, Matte Tin plated on Solder tails, Nickel underplating over all
2	Emc Spring	2	Stainless Steel SUS301 T=0.15	
1	Shell	1	Stainless Steel SUS316L T=0.15	Nickel Plating

PART NO.: SEE THE PART NUMBER CODE		DRAWN BY: HuangXiaoHao		GOLDCONN TECHNOLOGIES COMPANY LIMITED			
GENERAL TOLERANCES		CHECKED BY: liuzongliang					
x.xxxx	± ---	APPROVED BY: Jacky		TITLE USB TYPE C 24P PLUG CH0.25外器长度9.4(H3)			
x.xxx	± 0.10			UNIT	SCALE	SHEET NO.	DWG.NO.
x.xx	± 0.20			mm	1:1	1 OF 1	CM324-002
x.x	± 0.30						
ANGULAR	± --°						

