

TID NO. 2753

REV	ECN No.	DATE	REMARK
A0	NEW	2016.11.05	NEW RELEASE
A	---	2022.07.11	正式版
B	ECN202303004	2023.03.13	盖子过炉后松脱,干涉由0.2改为0.4
C	ECR230916-00	2023.09.16	修正图纸规格描述

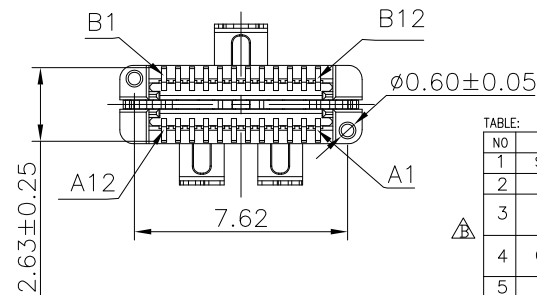
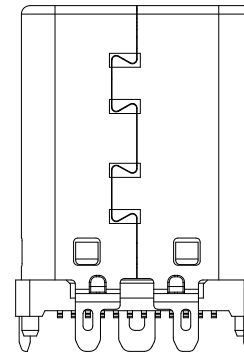
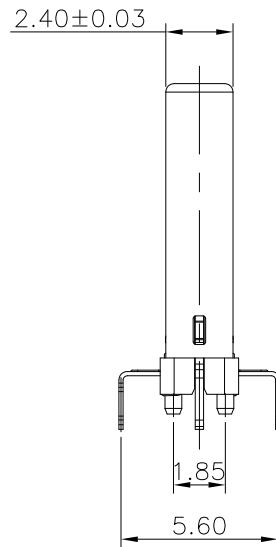
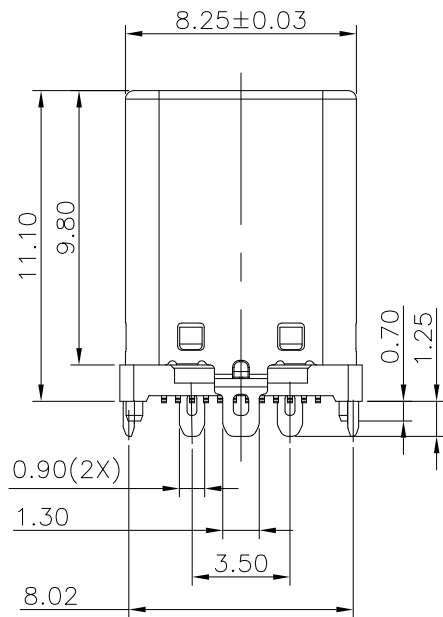
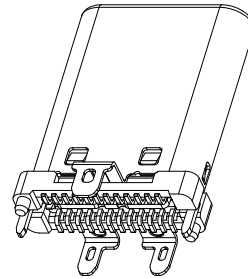
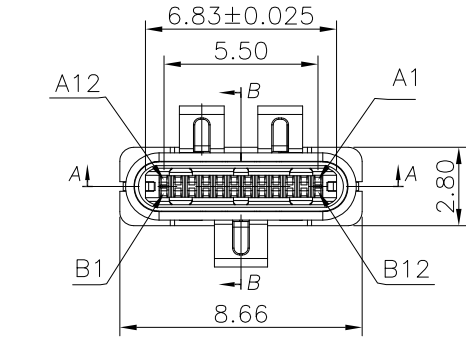

NOTE:

- ELECTRICAL PERFORMANCE,
  - CURRENT RATING:3A
  - VOLTAGE RATING:5V/20V DC/AC (RMS. MAX)
  - LLCR:
    - VBUS & GND PINS AND OTHER PINS: 40MΩ/PIN MAX.
    - SHIELD:50MΩ/MAX.
    - LLCR MAX. CHANGE OF ALL PINS: 10MΩ.
  - INSULATION RESISTANCE: 100MΩ MIN
  - DIELECTRIC WITHSTAND VOLTAGE,AC 100V FOR 1 MINUTE.
- MECHANICAL PERFORMANCE,
  - INSERTION FORCE: 5~20N.
  - EXTRACTION FORCE: 8~20N.
  - DURABILITY: 10000 CYCLES.
- ENVIRONMENTAL PERFORMANCE:
  - OPERATING TEMPERATURE: -25°C~+85°C.
- IR REFLOW:
  - THE PEAK TEMPERATURE ON THE BOARD SHALL BE MAINTAINED FOR 10 SECONDS AT 260°C.
- COMPLIANCE WITH ROHS REQUIREMENTS.
- SALT SPRAY:24H
- Meet ROHS & HF requirements

PIN DEFINITION:

A12	A11	A10	A9	A8	A7	A6	A5	A4	A3	A2	A1
GND	RX2+	RX2-	Vbus	SBU1	D-	D+	CC	Vbus	TX1-	TX1+	GND
B1	B2	B3	B4	B5	B6	B7	B8	B9	B10	B11	B12
GND	TX2+	TX2-	Vbus	Vconn	D+	D-	SBU2	Vbus	RX1-	RX1+	GND

PART NUMBER CODE:

Z-CM026 S L B XX X - A - 01  
① ② ③

- ① HOUSING COLOR:  
B:BLACK
- ② CONTACTS PLATED:  
01:接触区镀金3u", 焊接区镀锡80u"MIN
- ③ PACKING OPTIONS:  
R:TAPE & REEL  
VR:TAPE & REEL+Vacuum packaging (专用客户指定包装)

TABLE:

NO	PART	Q'TY	Material
1	SHELL	1	STAINLESS STEEL SUS304 T=0.15MM, Ni 30u" MIN. UNDER PLATED OVER ALL.
2	EMI	2	STAINLESS STEEL SUS301T=0.10MM,CLEAR ONLY
3	LATCH	1	STAINLESS STEEL SUS301 T=0.30MM,Ni 50u" MIN. UNDER PLATED OVER ALL. 80u" MIN. TIN PLATED ON SOLDER AREA.
4	CONTACT	24	COPPER STEEL C7025,Au(PART NUMBER CODE) plated on contact area Matte Tin plated 80u"min on solder area; Nickel 50u"min underplating over all.
5	HOUSING	1	LCP BLACK UL94 V-0
6	CAP	1	LCP BLACK UL94 V-0

PART NO.:		DRAWN BY:	GOLDCONN TECHNOLOGIES COMPANY LIMITED
SEE THE PART NUMBER CODE		HuangXiaoHao	
GENERAL TOLERANCES		CHECKED BY:	TITLE
x.xxxx	± ---	liuzongliang	
x.xxx	± 0.10	APPROVED BY:	USB TYPE-C 24P MALE Vertical H=11.1
x.xx	± 0.25	Jacky	
x.x	± 0.30	THIRD ANGLE PROJECTION	DIMENSIONS SCALE DRAWING SHEET NO. DWG.NO.
ANGULAR	± 3'		

TID NO. 2753

REV	ECN No.	DATE	REMARK
A0	NEW	2016.11.05	NEW RELEASE
A	---	2022.07.11	正式版
B	ECN202303004	2023.03.13	盖子过炉后松脱, 干涉由0.2改为0.4
C	ECR230916-00	2023.09.16	修正图纸规格描述

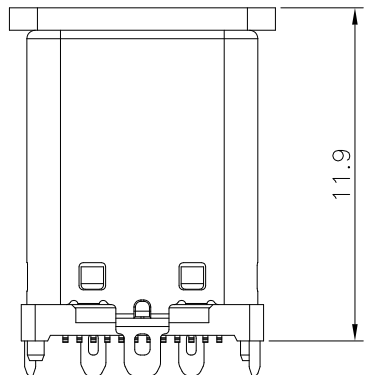
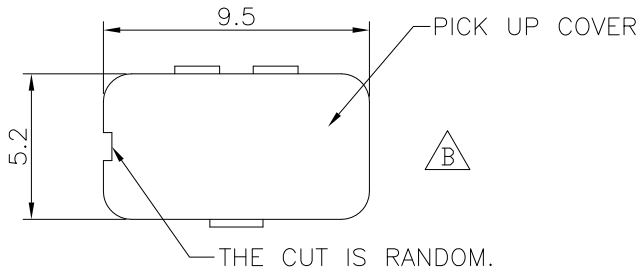
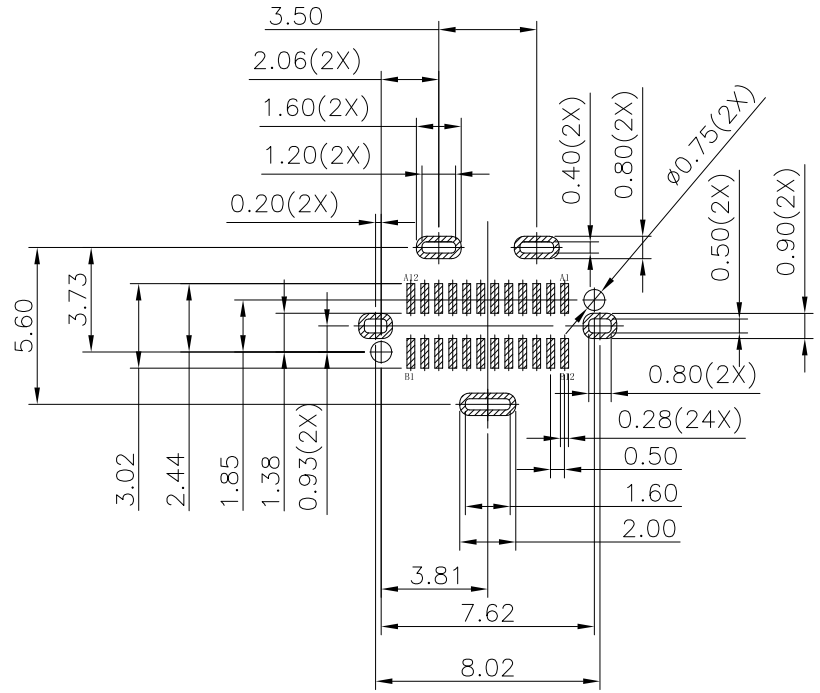
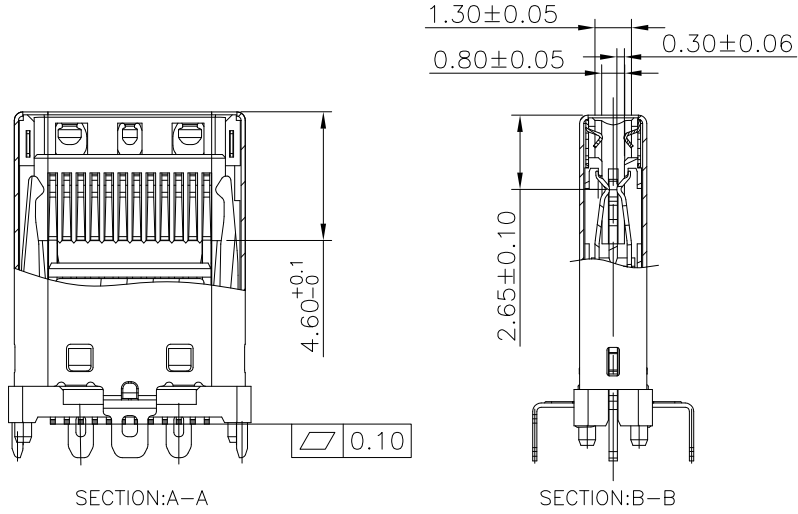

PART NO.: SEE THE PART NUMBER CODE		DRAWN BY: HuangXiaoHao		GOLDCONN TECHNOLOGIES COMPANY LIMITED	
GENERAL TOLERANCES		CHECKED BY: liuzongliang		TITLE	
x.xxx	$\pm$ ---	APPROVED BY: Jacky		USB TYPE-C 24P MALE Vertical H=11.1	
x.xxx	$\pm 0.10$	THIRD ANGLE PROJECTION		DIMENSIONS	
x.xx	$\pm 0.25$	mm		SCALE	DRAWING
x.x	$\pm 0.30$	mm		1:1	A4
ANGULAR	$\pm 3'$	mm		SHEET NO.	DWG.NO.
				2 OF 2	CM026-01